

# AER Series

## Specifications

### Gearbox Performance

Model No.	Stage	Ratio <sup>1</sup>	AER050	AER070	AER090	AER120	AER155	AER205	AER235	
Nominal output torque $T_{2N}$	1	3	9	36	90	195	342	588	1,140	
		4	12	48	120	260	520	1,040	1,680	
		5	15	60	150	325	650	1,200	2,000	
		6	18	55	150	310	600	1,100	1,900	
		7	19	50	140	300	550	1,100	1,800	
		8	17	45	120	260	500	1,000	1,600	
		9	14	40	100	230	450	900	1,500	
		10	14	40	100	230	450	900	1,500	
		14	-	42	140	300	550	1,100	1,800	
		20	-	40	100	230	450	900	1,500	
	2	15	14	-	-	-	-	-	-	-
		20	14	-	-	-	-	-	-	-
		25	15	60	150	325	650	1,200	2,000	
		30	20	55	150	310	600	1,100	1,900	
		35	19	50	140	300	550	1,100	1,800	
		40	17	45	120	260	500	1,000	1,600	
		45	14	40	100	230	450	900	1,500	
		50	14	60	100	230	650	1,200	2,000	
		60	20	55	150	310	600	1,100	1,900	
		70	19	50	140	300	550	1,100	1,800	
		80	17	45	120	260	500	1,000	1,600	
		90	14	40	100	230	450	900	1,500	
		100	14	40	100	230	450	900	1,500	
		120	-	-	150	310	600	1,100	1,900	
		140	-	-	140	300	550	1,100	1,800	
		160	-	-	120	260	550	1,000	1,600	
180	-	-	100	230	450	900	1,500			
200	-	-	100	230	450	900	1,500			
Emergency Stop Torque $T_{2NOT}$ <sup>2</sup>	Nm	1,2	3~200	3 times of nominal output torque						
Nominal Input Speed $n_{1N}$	rpm	1,2	3~200	5,000	5,000	4,000	4,000	3,000	3,000	2,000
Max. Input Speed $n_{1B}$	rpm	1,2	3~200	10,000	10,000	8,000	8,000	6,000	6,000	4,000
Backlash	arcmin	1	3~20	≤10	≤10	≤10	≤10	≤10	≤10	≤10
		2	25~200	≤14	≤14	≤14	≤14	≤14	≤14	≤14
Torsional Rigidity	Nm/arcmin	1,2	3~200	3	7	14	25	50	145	225
Max. radial load $F_{2rB}$ <sup>3</sup>	N	1,2	3~200	702	1,377	2,985	6,100	8,460	13,050	8,700
Max. axial load $F_{2aB}$ <sup>3</sup>	N	1,2	3~200	390	765	1,625	3,350	4,700	7,250	18,000
Service life	hr	1,2	3~200	20,000*						
Efficiency $\eta$	%	1	3~20	≥95%						
		2	25~200	≥92%						
Weight	kg	1	3~20	1.0	2.1	5.8	11.2	22.4	46.8	78.0
		2	25~200	1.3	2.0	4.6	11.1	21.8	43.7	81.9
Operating temp	°C	1,2	3~200	-10°C~90°C						
Lubrication				Synthetic lubrication oils						
Degree of gearbox protection		1,2	3~200	IP65						
Mounting position		1,2	3~200	all directions						
Noise Level ( $n_1=3000$ rpm, No Load)	dB(A)	1,2	3~200	≤61	≤63	≤65	≤68	≤70	≤72	≤74

### Gearbox Inertia

Model No.	Stage	Ratio <sup>1</sup>	AER050	AER070	AER090	AER120	AER155	AER205	AER235
Mass Moments of Inertia $J_1$	1	3~10	0.09	0.35	2.25	6.84	23.4	68.9	135.4
		14	-	0.07	1.87	6.25	21.8	65.6	119.8
		20	-	0.07	1.87	6.25	21.8	65.6	119.8
	2	15	0.09	-	-	-	-	-	-
		20	0.09	-	-	-	-	-	-
		25~100	0.09	0.09	0.35	2.25	6.84	23.4	68.9
120~200	-	-	0.31	1.87	6.25	21.8	65.6		

1. Ratio ( $i=N_{in}/N_{out}$ )

2.  $T_{2B} = 60\%$  of  $T_{2NOT}$

3. Applied to the output shaft center @ 100 rpm

★ S1 service life 10,000 hrs (Consult us)



# AER Series

## Dimensions (1-stage, Ratio $i=3\sim 20$ )

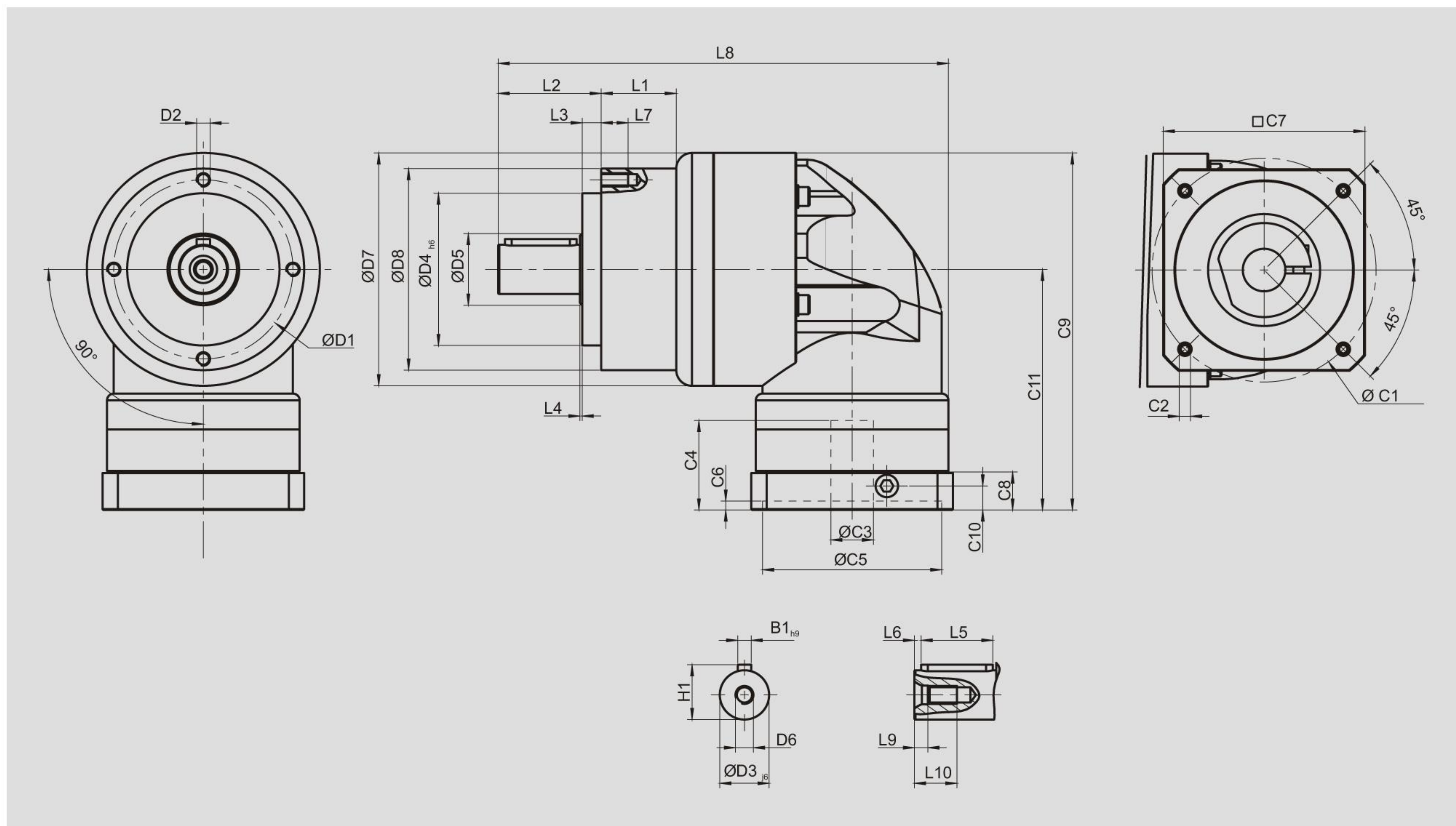

[unit: mm]

Dimension	AER050	AER070	AER090	AER120	AER155	AER205	AER235
D1	44	62	80	108	140	184	210
D2	M4 x 0.7P	M5 x 0.8P	M6 x 1P	M8 x 1.25P	M10 x 1.5P	M12 x 1.75P	M16 x 2P
D3 <sub>j6</sub>	12	16	22	32	40	55	75
D4 <sub>h6</sub>	35	52	68	90	120	160	180
D5	22	22	30	40	75	95	115
D6	M4 x 0.7P	M5 x 0.8P	M8 x 1.25P	M12 x 1.75P	M16 x 2P	M20 x 2.5P	M20 x 2.5P
D7	53	70	104	130	162	205	260
D8	50	70	90	120	155	205	235
L1	--	--	33.5	38	50	--	70
L2	24.5	36	46	70	97	100	126
L3	4	6.5	8.5	17.5	15	15	18
L4	1	1	1	1.5	3	3	3
L5	14	25	32	40	63	70	90
L6	2	2	3	5	5	6	7
L7	8	10	12	16	20	22	28
L8	115.5	146	201	252	324.5	379.5	461.5
L9	4.5	4.8	7.2	10	12	15	15
L10	10	12.5	19	28	36	42	42
C1 <sup>4</sup>	46	70	100	130	165	215	235
C2 <sup>4</sup>	M4 x 0.7P	M5 x 0.8P	M6 x 1P	M8 x 1.25P	M10 x 1.5P	M12 x 1.75P	M12 x 1.75P
C3 <sup>4</sup>	≤11 / ≤12	≤14 / ≤16	≤19 / ≤24	≤32	≤38	≤48	≤55
C4 <sup>4</sup>	30	34	40	50	60	85	116
C5 <sup>4</sup>	30	50	80	110	130	180	200
C6 <sup>4</sup>	3.5	8	4	5	6	6	6
C7 <sup>4</sup>	48	60	90	115	142	190	220
C8 <sup>4</sup>	19.5	19	17	19.5	22.5	29	63
C9 <sup>4</sup>	100.5	116.5	159.5	199	245.5	316	398.5
C10 <sup>4</sup>	13.25	13.5	10.75	13	15	20.75	53.5
C11 <sup>4</sup>	74	81.5	107.5	134	164.5	213.5	268.5
B1 <sub>h9</sub>	4	5	6	10	12	16	20
H1	14	18	24.5	35	43	59	79.5

4. C1~C11 are motor specific dimensions (metric std shown). Refer to Apexdyna.com and Design Tool to view your specific motor mounting system.



# Dimensions (2-stage, Ratio $i=25\sim 200$ )

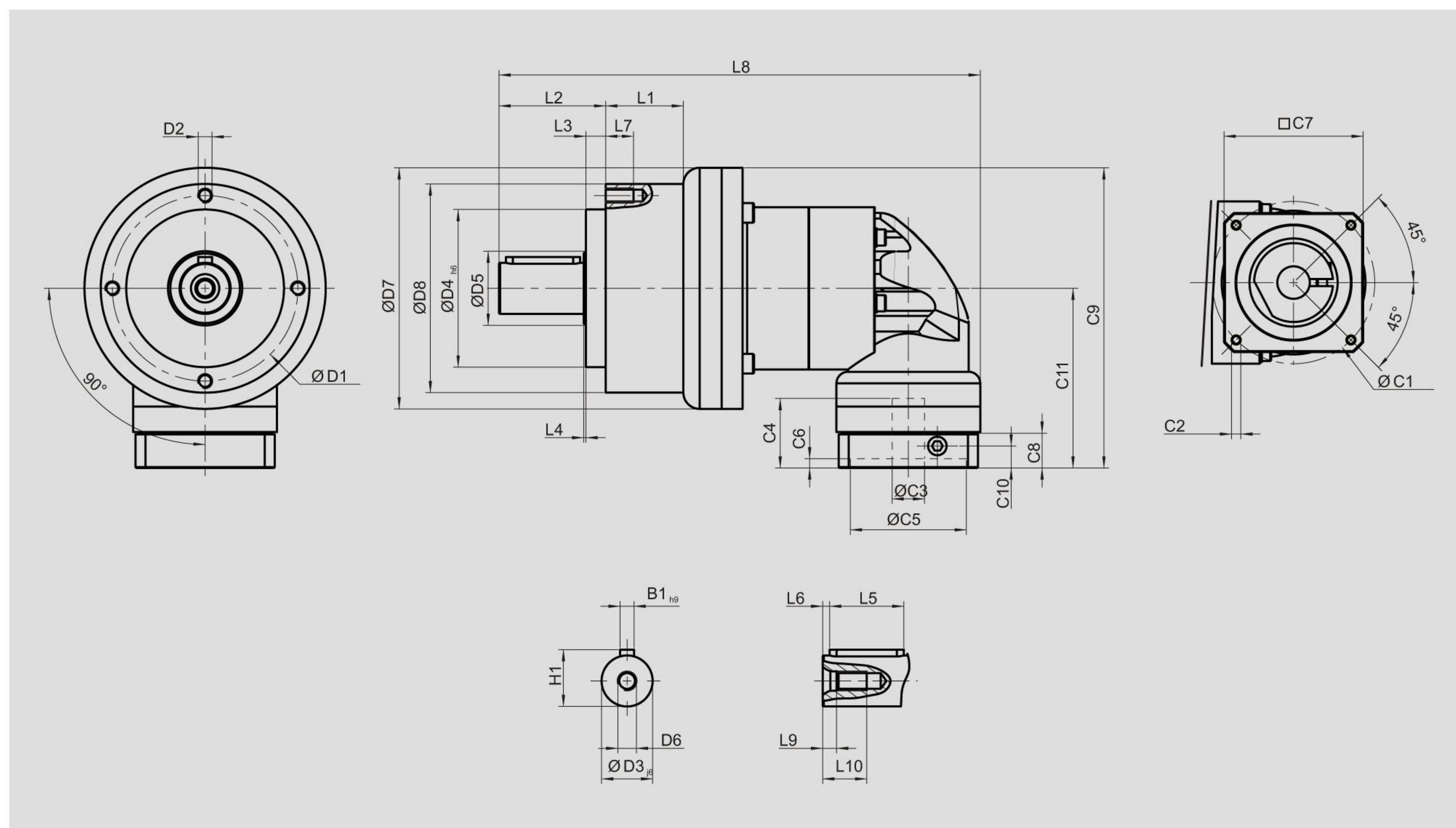

[unit: mm]

Dimension	AER050	AER070	AER090	AER120	AER155	AER205	AER235
D1	44	62	80	108	140	184	210
D2	M4 x 0.7P	M5 x 0.8P	M6 x 1P	M8 x 1.25P	M10 x 1.5P	M12 x 1.75P	M16 x 2P
D3 <sub>j6</sub>	12	16	22	32	40	55	75
D4 <sub>h6</sub>	35	52	68	90	120	160	180
D5	22	22	30	40	75	95	115
D6	M4 x 0.7P	M5 x 0.8P	M8 x 1.25P	M12 x 1.75P	M16 x 2P	M20 x 2.5P	M20 x 2.5P
D7	53	70	104	130	162	205	260
D8	50	70	90	120	155	205	235
L1	--	--	33.5	38	50	--	70
L2	24.5	36	46	70	97	100	126
L3	4	6.5	8.5	17.5	15	15	18
L4	1	1	1	1.5	3	3	3
L5	14	25	32	40	63	70	90
L6	2	2	3	5	5	6	7
L7	8	10	12	16	20	22	28
L8	142.5	167.5	207.5	283	358	422.5	506.5
L9	4.5	4.8	7.2	10	12	15	15
L10	10	12.5	19	28	36	42	42
C1 <sup>5</sup>	46	46	70	100	130	165	215
C2 <sup>5</sup>	M4 x 0.7P	M4 x 0.7P	M5 x 0.8P	M6 x 1P	M8 x 1.25P	M10 x 1.5P	M12 x 1.75P
C3 <sup>5</sup>	≤11 / ≤12	≤11 / ≤12	≤14 / ≤15.875 / ≤16	≤19 / ≤24	≤32	≤38	≤48
C4 <sup>5</sup>	30	30	34	40	50	60	85
C5 <sup>5</sup>	30	30	50	80	110	130	180
C6 <sup>5</sup>	3.5	3.5	8	4	5	6	6
C7 <sup>5</sup>	48	48	60	90	115	142	190
C8 <sup>5</sup>	19.5	19.5	19	17	19.5	22.5	29
C9 <sup>5</sup>	100.5	109	133.5	172.5	215	267	343.5
C10 <sup>5</sup>	13.25	13.25	13.5	10.75	13	15	20.75
C11 <sup>5</sup>	74	74	81.5	107.5	134	164.5	213.5
B1 <sub>h9</sub>	4	5	6	10	12	16	20
H1	14	18	24.5	35	43	59	79.5

5. C1~C11 are motor specific dimensions (metric std shown). Refer to Apexdyna.com and Design Tool to view your specific motor mounting system.